



**RUGGEDIZED LIGHT DUTY GLIDES**

LOW-PROFILE, FIXED STUD

1" BASE DIAMETER

**Ruggedized® Light Duty (RLD) Low-Profile, Poly Fixed Stud Glides**

The IEC Poly Base Ruggedized® Light Duty (RLD) Fixed Stud Glides are ideal for light to medium duty, high volume applications. The RLD series glides use advanced engineering design and composite materials to create a rugged glide while lowering the manufacturing costs of this product family. These RLD glides incorporate many features requested by commercial and retail customers. They come standard with your choice of Top-A-Just™ features: Internal top allen-drive broached hex (-BR) or external top slotted hex (-HX-SL) for a socket or open end wrench. Five (5) nylon base sizes to choose from: 1" to 3", 3/8" thick. Steel stud and washer with black trivalent zinc plating. Optional jam nut (add -JN to part number).

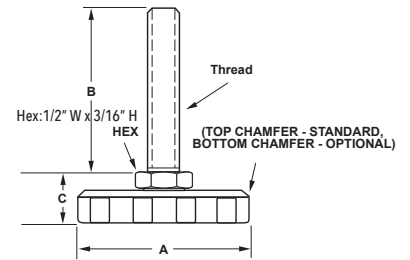

More thread sizes and lengths (including metric, stainless steel and female sockets) available for this base style in our Medium-Duty Leveler catalog.

**Features**

- Black trivalent zinc
- Top hex drive options
- Top slot feature
- Loads to 1500 lbs
- Corrosion resistant
- Non-swivel fixed base
- 5 base diameters
- Glass-filled nylon
- Optional jam nut (-JN)
- Optional Rubber Pad
- RoHS compliant

**Applications**

- Appliances
- Displays
- Racks
- Vending Machines
- Stages
- Decks
- Electronic equipment
- Enclosures
- Conveyors
- Machinery
- Work tables



Optional jam nut (add -JN to part number) →

TOP EXTERNAL SLOTTED HEX DRIVE (-HX-SL)	TOP ALLEN-DRIVE BROACHED HEX (-BR)
<p>1/4-20 Hex = 5/32 5/16-18 Hex = 7/32 3/8-16 Hex = 1/4 1/2-13 Hex = 5/16</p>	<p>Top allen-drive broached hex (-BR) Dimension table at bottom of page.</p>

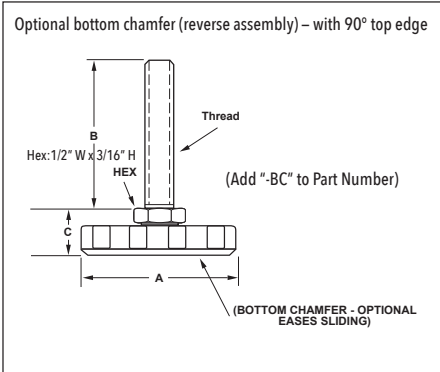

Steel	Steel with Rubber Pad	Load	Thread	A	B	C
IL7-RLD-4BX1-BR	IL7-RLD-4BX1-BR-P	100	1/4-20	1	1	5/8
IL7-RLD-4BX1-HX-SL	IL7-RLD-4BX1-HX-SL-P	100	1/4-20	1	1	5/8
IL7-RLD-4BX15-BR	IL7-RLD-4BX15-BR-P	100	1/4-20	1	1-1/2	5/8
IL7-RLD-4BX15-HX-SL	IL7-RLD-4BX15-HX-SL-P	100	1/4-20	1	1-1/2	5/8
IL7-RLD-4B-BR	IL7-RLD-4B-BR-P	100	1/4-20	1	2	5/8
IL7-RLD-4B-HX-SL	IL7-RLD-4B-HX-SL-P	100	1/4-20	1	2	5/8
IL7-RLD-5BX1-BR	IL7-RLD-5BX1-BR-P	400	5/16-18	1	1	5/8
IL7-RLD-5BX1-HX-SL	IL7-RLD-5BX1-HX-SL-P	400	5/16-18	1	1	5/8
IL7-RLD-5B-BR	IL7-RLD-5B-BR-P	400	5/16-18	1	2	5/8
IL7-RLD-5B-HX-SL	IL7-RLD-5B-HX-SL-P	400	5/16-18	1	2	5/8
IL7-RLD-5BX3-BR	IL7-RLD-5BX3-BR-P	400	5/16-18	1	3	5/8
IL7-RLD-5BX3-HX-SL	IL7-RLD-5BX3-HX-SL-P	400	5/16-18	1	3	5/8
IL7-RLD-6B-BR	IL7-RLD-6B-BR-P	750	3/8-16	1	2	5/8
IL7-RLD-6B-HX-SL	IL7-RLD-6B-HX-SL-P	750	3/8-16	1	2	5/8
IL7-RLD-6BX3-BR	IL7-RLD-6BX3-BR-P	750	3/8-16	1	3	5/8
IL7-RLD-6BX3-HX-SL	IL7-RLD-6BX3-HX-SL-P	750	3/8-16	1	3	5/8
IL7-RLD-6BX4-BR	IL7-RLD-6BX4-BR-P	750	3/8-16	1	4	5/8
IL7-RLD-6BX4-HX-SL	IL7-RLD-6BX4-HX-SL-P	750	3/8-16	1	4	5/8
IL7-RLD-7B-BR	IL7-RLD-7B-BR-P	1500	1/2-13	1	2	5/8
IL7-RLD-7B-HX-SL	IL7-RLD-7B-HX-SL-P	1500	1/2-13	1	2	5/8
IL7-RLD-7BX3-BR	IL7-RLD-7BX3-BR-P	1500	1/2-13	1	3	5/8
IL7-RLD-7BX3-HX-SL	IL7-RLD-7BX3-HX-SL-P	1500	1/2-13	1	3	5/8
IL7-RLD-7BX4-BR	IL7-RLD-7BX4-BR-P	1500	1/2-13	1	4	5/8
IL7-RLD-7BX4-HX-SL	IL7-RLD-7BX4-HX-SL-P	1500	1/2-13	1	4	5/8



Poly Fixed Socket/Stud with Rubber Pad (Pad Bottom View)

Standard finish is black zinc. For silver or gold finish (as shown above) see IEC's Medium-Duty Leveler catalog.

More thread sizes and length options for this poly fixed base design in IEC's Medium-Duty Leveler catalog.

To order optional jam nut add "-JN" to part number.  
Top broached hex, "allen drive," (-BR) Thread & Hex Size table below:  
(For 5/8-11 thru 1-1/4-7 thread sizes, see IEC's Medium-Duty Leveler catalog.)

Top Hex (Allen-drive) Thread & Hex Size								
Thread	1/4-20	5/16-18	3/8-16	1/2-13	5/8-11	3/4-10	1-8	1-1/4-7
Hex Size	1/8	5/32	3/16	1/4	5/16	3/8	9/16	5/8



**INTERNATIONAL EQUIPMENT COMPONENTS, INC.**

Phone: 562.597.4533 eMail: sales@iec-corp.com

Web: www.iec-corp.com | www.levelingmounts.com

**RUGGEDIZED LIGHT DUTY GLIDES**

LOW-PROFILE, FIXED STUD

1-1/2" BASE DIAMETER

**Ruggedized® Light Duty (RLD) Low-Profile, Poly Fixed Stud Glides**

The IEC Poly Base Ruggedized® Light Duty (RLD) Fixed Stud Glides are ideal for light to medium duty, high volume applications. The RLD series glides use advanced engineering design and composite materials to create a rugged glide while lowering the manufacturing costs of this product family. These RLD glides incorporate many features requested by commercial and retail customers. They come standard with your choice of Top-A-Just™ features: Internal top allen-drive broached hex (-BR) or external top slotted hex (-HX-SL) for a socket or open end wrench. Five (5) nylon base sizes to choose from: 1" to 3", 3/8" thick. Steel stud and washer with black trivalent zinc plating. Optional jam nut (add -JN to part number).

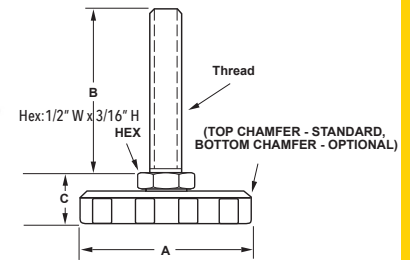

More thread sizes and lengths (including metric, stainless steel and female sockets) available for this base style in our Medium-Duty Leveler catalog.

**Features**

- Black trivalent zinc
- Top hex drive options
- Top slot feature
- Loads to 1500 lbs
- Corrosion resistant
- Non-swivel fixed base
- 5 base diameters
- Glass-filled nylon
- Optional jam nut (-JN)
- Optional Rubber Pad
- RoHS compliant

**Applications**

- Appliances
- Displays
- Racks
- Vending Machines
- Stages
- Decks
- Electronic equipment
- Enclosures
- Conveyors
- Machinery
- Work tables

Optional jam nut (add -JN to part number) →



TOP EXTERNAL SLOTTED HEX DRIVE (-HX-SL)		TOP ALLEN-DRIVE BROACHED HEX (-BR)	
	<p>1/4-20 Hex = 5/32</p> <p>5/16-18 Hex = 7/32</p> <p>3/8-16 Hex = 1/4</p> <p>1/2-13 Hex = 5/16</p>		<p>Top allen-drive broached hex (-BR)</p> <p>Dimension table at bottom of page.</p>

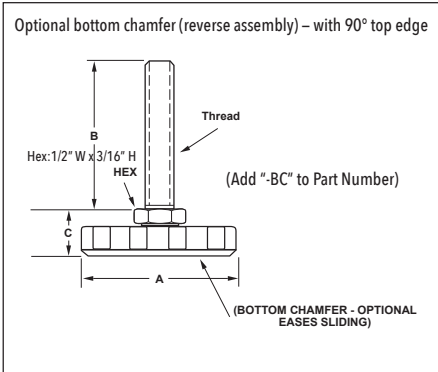

Steel	Steel with Rubber Pad	Load	Thread	A	B	C
IL8-RLD-4BX1-BR	IL8-RLD-4BX1-BR-P	100	1/4-20	1-1/2	1	5/8
IL8-RLD-4BX1-HX-SL	IL8-RLD-4BX1-HX-SL-P	100	1/4-20	1-1/2	1	5/8
IL8-RLD-4BX15-BR	IL8-RLD-4BX15-BR-P	100	1/4-20	1-1/2	1-1/2	5/8
IL8-RLD-4BX15-HX-SL	IL8-RLD-4BX15-HX-SL-P	100	1/4-20	1-1/2	1-1/2	5/8
IL8-RLD-4B-BR	IL8-RLD-4B-BR-P	100	1/4-20	1-1/2	2	5/8
IL8-RLD-4B-HX-SL	IL8-RLD-4B-HX-SL-P	100	1/4-20	1-1/2	2	5/8
IL8-RLD-5BX1-BR	IL8-RLD-5BX1-BR-P	400	5/16-18	1-1/2	1	5/8
IL8-RLD-5BX1-HX-SL	IL8-RLD-5BX1-HX-SL-P	400	5/16-18	1-1/2	1	5/8
IL8-RLD-5B-BR	IL8-RLD-5B-BR-P	400	5/16-18	1-1/2	2	5/8
IL8-RLD-5B-HX-SL	IL8-RLD-5B-HX-SL-P	400	5/16-18	1-1/2	2	5/8
IL8-RLD-5BX3-BR	IL8-RLD-5BX3-BR-P	400	5/16-18	1-1/2	3	5/8
IL8-RLD-5BX3-HX-SL	IL8-RLD-5BX3-HX-SL-P	400	5/16-18	1-1/2	3	5/8
IL8-RLD-6B-BR	IL8-RLD-6B-BR-P	750	3/8-16	1-1/2	2	5/8
IL8-RLD-6B-HX-SL	IL8-RLD-6B-HX-SL-P	750	3/8-16	1-1/2	2	5/8
IL8-RLD-6BX3-BR	IL8-RLD-6BX3-BR-P	750	3/8-16	1-1/2	3	5/8
IL8-RLD-6BX3-HX-SL	IL8-RLD-6BX3-HX-SL-P	750	3/8-16	1-1/2	3	5/8
IL8-RLD-6BX4-BR	IL8-RLD-6BX4-BR-P	750	3/8-16	1-1/2	4	5/8
IL8-RLD-6BX4-HX-SL	IL8-RLD-6BX4-HX-SL-P	750	3/8-16	1-1/2	4	5/8
IL8-RLD-7B-BR	IL8-RLD-7B-BR-P	1500	1/2-13	1-1/2	2	5/8
IL8-RLD-7B-HX-SL	IL8-RLD-7B-HX-SL-P	1500	1/2-13	1-1/2	2	5/8
IL8-RLD-7BX3-BR	IL8-RLD-7BX3-BR-P	1500	1/2-13	1-1/2	3	5/8
IL8-RLD-7BX3-HX-SL	IL8-RLD-7BX3-HX-SL-P	1500	1/2-13	1-1/2	3	5/8
IL8-RLD-7BX4-BR	IL8-RLD-7BX4-BR-P	1500	1/2-13	1-1/2	4	5/8
IL8-RLD-7BX4-HX-SL	IL8-RLD-7BX4-HX-SL-P	1500	1/2-13	1-1/2	4	5/8



Poly Fixed Socket/Stud with Rubber Pad (Pad Bottom View)

Standard finish is black zinc. For silver or gold finish (as shown above) see IEC's Medium-Duty Leveler catalog.

More thread sizes and length options for this poly fixed base design in IEC's Medium-Duty Leveler catalog.

To order optional jam nut add "-JN" to part number.

Top broached hex, "allen drive," (-BR) Thread & Hex Size table below:

(For 5/8-11 thru 1-1/4-7 thread sizes, see IEC's Medium-Duty Leveler catalog.)

Top Hex (Allen-drive) Thread & Hex Size								
Thread	1/4-20	5/16-18	3/8-16	1/2-13	5/8-11	3/4-10	1-8	1-1/4-7
Hex Size	1/8	5/32	3/16	1/4	5/16	3/8	9/16	5/8



**INTERNATIONAL EQUIPMENT COMPONENTS, INC.**

Phone: 562.597.4533 eMail: sales@iec-corp.com

Web: www.iec-corp.com | www.levelingmounts.com

**RUGGEDIZED LIGHT DUTY GLIDES**

LOW-PROFILE, FIXED STUD

2" BASE DIAMETER

**Ruggedized® Light Duty (RLD) Low-Profile, Poly Fixed Stud Glides**

The IEC Poly Base Ruggedized® Light Duty (RLD) Fixed Stud Glides are ideal for light to medium duty, high volume applications. The RLD series glides use advanced engineering design and composite materials to create a rugged glide while lowering the manufacturing costs of this product family. These RLD glides incorporate many features requested by commercial and retail customers. They come standard with your choice of Top-A-Just™ features: Internal top allen-drive broached hex (-BR) or external top slotted hex (-HX-SL) for a socket or open end wrench. Five (5) nylon base sizes to choose from: 1" to 3", 3/8" thick. Steel stud and washer with black trivalent zinc plating. Optional jam nut (add -JN to part number).

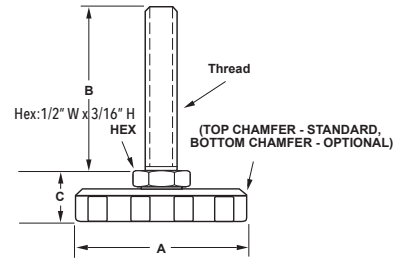

More thread sizes and lengths (including metric, stainless steel and female sockets) available for this base style in our Medium-Duty Leveler catalog.

**Features**

- Black trivalent zinc
- Top hex drive options
- Top slot feature
- Loads to 1500 lbs
- Corrosion resistant
- Non-swivel fixed base
- 5 base diameters
- Glass-filled nylon
- Optional jam nut (-JN)
- Optional Rubber Pad
- RoHS compliant

**Applications**

- Appliances
- Displays
- Racks
- Vending Machines
- Stages
- Decks
- Electronic equipment
- Enclosures
- Conveyors
- Machinery
- Work tables



Optional jam nut (add -JN to part number) →

TOP EXTERNAL SLOTTED HEX DRIVE (-HX-SL)		TOP ALLEN-DRIVE BROACHED HEX (-BR)	
	<p>1/4-20 Hex = 5/32</p> <p>5/16-18 Hex = 7/32</p> <p>3/8-16 Hex = 1/4</p> <p>1/2-13 Hex = 5/16</p>		<p>Top allen-drive broached hex (-BR)</p> <p>Dimension table at bottom of page.</p>

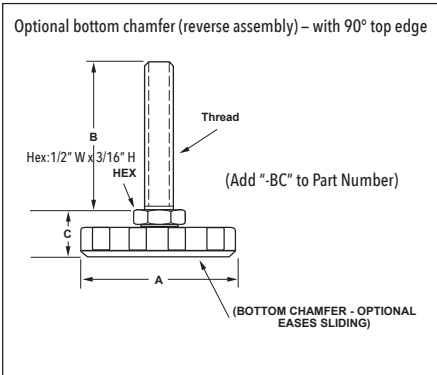

Steel	Steel with Rubber Pad	Load	Thread	A	B	C
IL7A-RLD-4BX1-BR	IL7A-RLD-4BX1-BR-P	100	1/4-20	2	1	5/8
IL7A-RLD-4BX1-HX-SL	IL7A-RLD-4BX1-HX-SL-P	100	1/4-20	2	1	5/8
IL7A-RLD-4BX15-BR	IL7A-RLD-4BX15-BR-P	100	1/4-20	2	1-1/2	5/8
IL7A-RLD-4BX15-HX-SL	IL7A-RLD-4BX15-HX-SL-P	100	1/4-20	2	1-1/2	5/8
IL7A-RLD-4B-BR	IL7A-RLD-4B-BR-P	100	1/4-20	2	2	5/8
IL7A-RLD-4B-HX-SL	IL7A-RLD-4B-HX-SL-P	100	1/4-20	2	2	5/8
IL7A-RLD-5BX1-BR	IL7A-RLD-5BX1-BR-P	400	5/16-18	2	1	5/8
IL7A-RLD-5BX1-HX-SL	IL7A-RLD-5BX1-HX-SL-P	400	5/16-18	2	1	5/8
IL7A-RLD-5B-BR	IL7A-RLD-5B-BR-P	400	5/16-18	2	2	5/8
IL7A-RLD-5B-HX-SL	IL7A-RLD-5B-HX-SL-P	400	5/16-18	2	2	5/8
IL7A-RLD-5BX3-BR	IL7A-RLD-5BX3-BR-P	400	5/16-18	2	3	5/8
IL7A-RLD-5BX3-HX-SL	IL7A-RLD-5BX3-HX-SL-P	400	5/16-18	2	3	5/8
IL7A-RLD-6B-BR	IL7A-RLD-6B-BR-P	750	3/8-16	2	2	5/8
IL7A-RLD-6B-HX-SL	IL7A-RLD-6B-HX-SL-P	750	3/8-16	2	2	5/8
IL7A-RLD-6BX3-BR	IL7A-RLD-6BX3-BR-P	750	3/8-16	2	3	5/8
IL7A-RLD-6BX3-HX-SL	IL7A-RLD-6BX3-HX-SL-P	750	3/8-16	2	3	5/8
IL7A-RLD-6BX4-BR	IL7A-RLD-6BX4-BR-P	750	3/8-16	2	4	5/8
IL7A-RLD-6BX4-HX-SL	IL7A-RLD-6BX4-HX-SL-P	750	3/8-16	2	4	5/8
IL7A-RLD-7B-BR	IL7A-RLD-7B-BR-P	1500	1/2-13	2	2	5/8
IL7A-RLD-7B-HX-SL	IL7A-RLD-7B-HX-SL-P	1500	1/2-13	2	2	5/8
IL7A-RLD-7BX3-BR	IL7A-RLD-7BX3-BR-P	1500	1/2-13	2	3	5/8
IL7A-RLD-7BX3-HX-SL	IL7A-RLD-7BX3-HX-SL-P	1500	1/2-13	2	3	5/8
IL7A-RLD-7BX4-BR	IL7A-RLD-7BX4-BR-P	1500	1/2-13	2	4	5/8
IL7A-RLD-7BX4-HX-SL	IL7A-RLD-7BX4-HX-SL-P	1500	1/2-13	2	4	5/8



Poly Fixed Socket/Stud with Rubber Pad (Pad Bottom View)

Standard finish is black zinc. For silver or gold finish (as shown above) see IEC's Medium-Duty Leveler catalog.

More thread sizes and length options for this poly fixed base design in IEC's Medium-Duty Leveler catalog.

To order optional jam nut add "-JN" to part number.

Top broached hex, "allen drive," (-BR) Thread & Hex Size table below:

(For 5/8-11 thru 1-1/4-7 thread sizes, see IEC's Medium-Duty Leveler catalog.)

Top Hex (Allen-drive) Thread & Hex Size								
Thread	1/4-20	5/16-18	3/8-16	1/2-13	5/8-11	3/4-10	1-8	1-1/4-7
Hex Size	1/8	5/32	3/16	1/4	5/16	3/8	9/16	5/8



**RUGGEDIZED LIGHT DUTY GLIDES**  
 LOW-PROFILE, FIXED STUD  
 2-1/2" BASE DIAMETER

**Ruggedized® Light Duty (RLD) Low-Profile, Poly Fixed Stud Glides**

The IEC Poly Base Ruggedized® Light Duty (RLD) Fixed Stud Glides are ideal for light to medium duty, high volume applications. The RLD series glides use advanced engineering design and composite materials to create a rugged glide while lowering the manufacturing costs of this product family. These RLD glides incorporate many features requested by commercial and retail customers. They come standard with your choice of Top-A-Just™ features: Internal top allen-drive broached hex (-BR) or external top slotted hex (-HX-SL) for a socket or open end wrench. Five (5) nylon base sizes to choose from: 1" to 3", 3/8" thick. Steel stud and washer with black trivalent zinc plating. Optional jam nut (add -JN to part number).

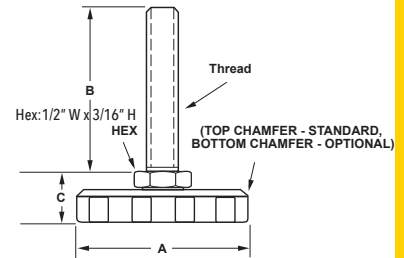

More thread sizes and lengths (including metric, stainless steel and female sockets) available for this base style in our Medium-Duty Leveler catalog.

**Features**

- Black trivalent zinc
- Top hex drive options
- Top slot feature
- Loads to 1500 lbs
- Corrosion resistant
- Non-swivel fixed base
- 5 base diameters
- Glass-filled nylon
- Optional jam nut (-JN)
- Optional Rubber Pad
- RoHS compliant

**Applications**

- Appliances
- Displays
- Racks
- Vending Machines
- Stages
- Decks
- Electronic equipment
- Enclosures
- Conveyors
- Machinery
- Work tables



Optional jam nut (add -JN to part number) →

TOP EXTERNAL SLOTTED HEX DRIVE (-HX-SL)		TOP ALLEN-DRIVE BROACHED HEX (-BR)	
	1/4-20 Hex = 5/32 5/16-18 Hex = 7/32 3/8-16 Hex = 1/4 1/2-13 Hex = 5/16		Top allen-drive broached hex (-BR) Dimension table at bottom of page.

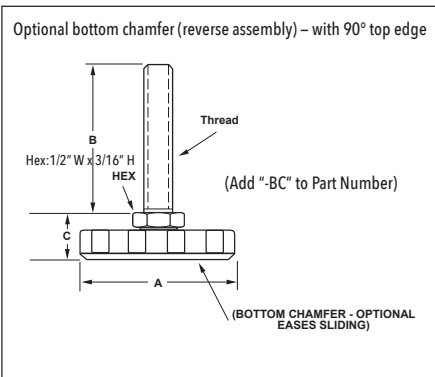

Steel	Steel with Rubber Pad	Load	Thread	A	B	C
IL7M-RLD-4BX1-BR	IL7M-RLD-4BX1-BR-P	100	1/4-20	2-1/2	1	5/8
IL7M-RLD-4BX1-HX-SL	IL7M-RLD-4BX1-HX-SL-P	100	1/4-20	2-1/2	1	5/8
IL7M-RLD-4BX15-BR	IL7M-RLD-4BX15-BR-P	100	1/4-20	2-1/2	1-1/2	5/8
IL7M-RLD-4BX15-HX-SL	IL7M-RLD-4BX15-HX-SL-P	100	1/4-20	2-1/2	1-1/2	5/8
IL7M-RLD-4B-BR	IL7M-RLD-4B-BR-P	100	1/4-20	2-1/2	2	5/8
IL7M-RLD-4B-HX-SL	IL7M-RLD-4B-HX-SL-P	100	1/4-20	2-1/2	2	5/8
IL7M-RLD-5BX1-BR	IL7M-RLD-5BX1-BR-P	400	5/16-18	2-1/2	1	5/8
IL7M-RLD-5BX1-HX-SL	IL7M-RLD-5BX1-HX-SL-P	400	5/16-18	2-1/2	1	5/8
IL7M-RLD-5B-BR	IL7M-RLD-5B-BR-P	400	5/16-18	2-1/2	2	5/8
IL7M-RLD-5B-HX-SL	IL7M-RLD-5B-HX-SL-P	400	5/16-18	2-1/2	2	5/8
IL7M-RLD-5BX3-BR	IL7M-RLD-5BX3-BR-P	400	5/16-18	2-1/2	3	5/8
IL7M-RLD-5BX3-HX-SL	IL7M-RLD-5BX3-HX-SL-P	400	5/16-18	2-1/2	3	5/8
IL7M-RLD-6B-BR	IL7M-RLD-6B-BR-P	750	3/8-16	2-1/2	2	5/8
IL7M-RLD-6B-HX-SL	IL7M-RLD-6B-HX-SL-P	750	3/8-16	2-1/2	2	5/8
IL7M-RLD-6BX3-BR	IL7M-RLD-6BX3-BR-P	750	3/8-16	2-1/2	3	5/8
IL7M-RLD-6BX3-HX-SL	IL7M-RLD-6BX3-HX-SL-P	750	3/8-16	2-1/2	3	5/8
IL7M-RLD-6BX4-BR	IL7M-RLD-6BX4-BR-P	750	3/8-16	2-1/2	4	5/8
IL7M-RLD-6BX4-HX-SL	IL7M-RLD-6BX4-HX-SL-P	750	3/8-16	2-1/2	4	5/8
IL7M-RLD-7B-BR	IL7M-RLD-7B-BR-P	1500	1/2-13	2-1/2	2	5/8
IL7M-RLD-7B-HX-SL	IL7M-RLD-7B-HX-SL-P	1500	1/2-13	2-1/2	2	5/8
IL7M-RLD-7BX3-BR	IL7M-RLD-7BX3-BR-P	1500	1/2-13	2-1/2	3	5/8
IL7M-RLD-7BX3-HX-SL	IL7M-RLD-7BX3-HX-SL-P	1500	1/2-13	2-1/2	3	5/8
IL7M-RLD-7BX4-BR	IL7M-RLD-7BX4-BR-P	1500	1/2-13	2-1/2	4	5/8
IL7M-RLD-7BX4-HX-SL	IL7M-RLD-7BX4-HX-SL-P	1500	1/2-13	2-1/2	4	5/8



Poly Fixed Socket/Stud with Rubber Pad (Pad Bottom View)

Standard finish is black zinc. For silver or gold finish (as shown above) see IEC's Medium-Duty Leveler catalog.

More thread sizes and length options for this poly fixed base design in IEC's Medium-Duty Leveler catalog.

To order optional jam nut add "-JN" to part number.  
 Top broached hex, "allen drive," (-BR) Thread & Hex Size table below:  
 (For 5/8-11 thru 1-1/4-7 thread sizes, see IEC's Medium-Duty Leveler catalog.)

Top Hex (Allen-drive) Thread & Hex Size								
Thread	1/4-20	5/16-18	3/8-16	1/2-13	5/8-11	3/4-10	1-8	1-1/4-7
Hex Size	1/8	5/32	3/16	1/4	5/16	3/8	9/16	5/8



**RUGGEDIZED LIGHT DUTY GLIDES**

LOW-PROFILE, FIXED STUD

3" BASE DIAMETER

**Ruggedized® Light Duty (RLD) Low-Profile, Poly Fixed Stud Glides**

The IEC Poly Base Ruggedized® Light Duty (RLD) Fixed Stud Glides are ideal for light to medium duty, high volume applications. The RLD series glides use advanced engineering design and composite materials to create a rugged glide while lowering the manufacturing costs of this product family. These RLD glides incorporate many features requested by commercial and retail customers. They come standard with your choice of Top-A-Just™ features: Internal top allen-drive broached hex (-BR) or external top slot-ted hex (-HX-SL) for a socket or open end wrench. Five (5) nylon base sizes to choose from: 1" to 3", 3/8" thick. Steel stud and washer with black trivalent zinc plating. Optional jam nut (add -JN to part number).

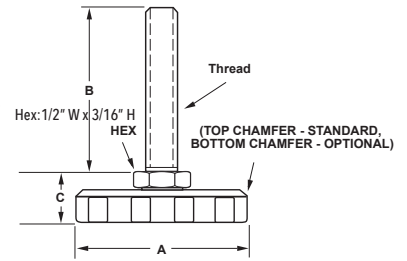

More thread sizes and lengths (including metric, stainless steel and female sockets) available for this base style in our Medium-Duty Leveler catalog.

**Features**

- Black trivalent zinc
- Top hex drive options
- Top slot feature
- Loads to 1500 lbs
- Corrosion resistant
- Non-swivel fixed base
- 5 base diameters
- Glass-filled nylon
- Optional jam nut (-JN)
- Optional Rubber Pad
- RoHS compliant

**Applications**

- Appliances
- Displays
- Racks
- Vending Machines
- Stages
- Decks
- Electronic equipment
- Enclosures
- Conveyors
- Machinery
- Work tables

Optional jam nut (add -JN to part number) →



TOP EXTERNAL SLOTTED HEX DRIVE (-HX-SL)		TOP ALLEN-DRIVE BROACHED HEX (-BR)	
	1/4-20 Hex = 5/32 5/16-18 Hex = 7/32 3/8-16 Hex = 1/4 1/2-13 Hex = 5/16		Top allen-drive broached hex (-BR) Dimension table at bottom of page.

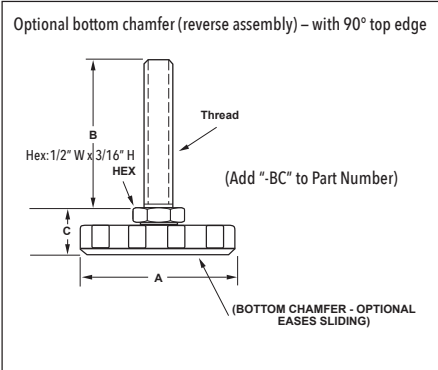

Steel	Steel with Rubber Pad	Load	Thread	A	B	C
IL8A-RLD-4BX1-BR	IL8A-RLD-4BX1-BR-P	100	1/4-20	3	1	5/8
IL8A-RLD-4BX1-HX-SL	IL8A-RLD-4BX1-HX-SL-P	100	1/4-20	3	1	5/8
IL8A-RLD-4BX15-BR	IL8A-RLD-4BX15-BR-P	100	1/4-20	3	1-1/2	5/8
IL8A-RLD-4BX15-HX-SL	IL8A-RLD-4BX15-HX-SL-P	100	1/4-20	3	1-1/2	5/8
IL8A-RLD-4B-BR	IL8A-RLD-4B-BR-P	100	1/4-20	3	2	5/8
IL8A-RLD-4B-HX-SL	IL8A-RLD-4B-HX-SL-P	100	1/4-20	3	2	5/8
IL8A-RLD-5BX1-BR	IL8A-RLD-5BX1-BR-P	400	5/16-18	3	1	5/8
IL8A-RLD-5BX1-HX-SL	IL8A-RLD-5BX1-HX-SL-P	400	5/16-18	3	1	5/8
IL8A-RLD-5B-BR	IL8A-RLD-5B-BR-P	400	5/16-18	3	2	5/8
IL8A-RLD-5B-HX-SL	IL8A-RLD-5B-HX-SL-P	400	5/16-18	3	2	5/8
IL8A-RLD-5BX3-BR	IL8A-RLD-5BX3-BR-P	400	5/16-18	3	3	5/8
IL8A-RLD-5BX3-HX-SL	IL8A-RLD-5BX3-HX-SL-P	400	5/16-18	3	3	5/8
IL8A-RLD-6B-BR	IL8A-RLD-6B-BR-P	750	3/8-16	3	2	5/8
IL8A-RLD-6B-HX-SL	IL8A-RLD-6B-HX-SL-P	750	3/8-16	3	2	5/8
IL8A-RLD-6BX3-BR	IL8A-RLD-6BX3-BR-P	750	3/8-16	3	3	5/8
IL8A-RLD-6BX3-HX-SL	IL8A-RLD-6BX3-HX-SL-P	750	3/8-16	3	3	5/8
IL8A-RLD-6BX4-BR	IL8A-RLD-6BX4-BR-P	750	3/8-16	3	4	5/8
IL8A-RLD-6BX4-HX-SL	IL8A-RLD-6BX4-HX-SL-P	750	3/8-16	3	4	5/8
IL8A-RLD-7B-BR	IL8A-RLD-7B-BR-P	1500	1/2-13	3	2	5/8
IL8A-RLD-7B-HX-SL	IL8A-RLD-7B-HX-SL-P	1500	1/2-13	3	2	5/8
IL8A-RLD-7BX3-BR	IL8A-RLD-7BX3-BR-P	1500	1/2-13	3	3	5/8
IL8A-RLD-7BX3-HX-SL	IL8A-RLD-7BX3-HX-SL-P	1500	1/2-13	3	3	5/8
IL8A-RLD-7BX4-BR	IL8A-RLD-7BX4-BR-P	1500	1/2-13	3	4	5/8
IL8A-RLD-7BX4-HX-SL	IL8A-RLD-7BX4-HX-SL-P	1500	1/2-13	3	4	5/8



Poly Fixed Socket/Stud with Rubber Pad (Pad Bottom View)

Standard finish is black zinc. For silver or gold finish (as shown above) see IEC's Medium-Duty Leveler catalog.

More thread sizes and length options for this poly fixed base design in IEC's Medium-Duty Leveler catalog.

To order optional jam nut add "-JN" to part number.  
 Top broached hex, "allen drive," (-BR) Thread & Hex Size table below:  
 (For 5/8-11 thru 1-1/4-7 thread sizes, see IEC's Medium-Duty Leveler catalog.)

Top Hex (Allen-drive) Thread & Hex Size								
Thread	1/4-20	5/16-18	3/8-16	1/2-13	5/8-11	3/4-10	1-8	1-1/4-7
Hex Size	1/8	5/32	3/16	1/4	5/16	3/8	9/16	5/8